



## Installation and Maintenance Manual for Driveway Heavy and Light Lifting Gate Hinges



### **Upswung Hydraulic Vehicular Lifting Driveway Gate Hinges**

The Upswung Hydraulic Vehicular Lifting Driveway Gate Hinge. It offers a complete operating range for Driveway Grades of 15%, 30% and 50% (SNOW GATES) with spring counterbalancing. Features include mutli-user, step-by-step, step-by-step with automatic reclosing, pedestrian gate, and Power Boost. Adjustment functions (run time, pause time, phase shift and motor power). It is versatile because of its options (4 limit switches, pre-flashing, flashing light controlled by control unit, courtesy light, cut-out of unused inputs with dip switches, built-in or plug-in radio). Easy to install with control LEDs, the extractable terminal boards and the silk-screen printing on the printed circuit indicating connections and functions.

Upswung LLC declines all responsibility for any inaccuracies contained in this manual and reserves the right to make modifications – without prior notice.

# Upswung Hydraulic Vehicular Lifting Driveway Gate Hinges

## Table of Contents

DESCRIPTION	PAGE
Site Placement.....	3
Pier Construction.....	4-6
Gate Hinge Mounting.....	7
Counter Balancing the Gate Barrier.....	8
Other Mounting Information.....	9
Hydraulic Adjustments.....	10
Specifications & Capacities .....	11
Safety Information .....	12
Wiring Information .....	13
Primary Voltage Wiring.....	14
Control Wiring.....	15-17
Control Panel Layout .....	18
Troubleshooting.....	19
System Checkout, Warrantee .....	20
Parts Identification .....	21
Maintenance Schedule .....	22

## Parts & Components

Inspect the operator for possible shipping damage or shortage of parts. Check all accessories as listed below. These do not include any accessories that were ordered separately.

DESCRIPTION	QUANTITY
Model HL410 Drive Unit	1
Upswung Lifting gate hinge assembly	1
Touch up paint	1
Touch up paint Brush	1
Model F4 PLUS Controller	1
Disconnect Key	1
Gate Caution Plate	2

- Gate Caution Plates are to be installed on the gate in a position where they can be easily seen.
  - CE listings are valid only if an Upswung LLC drive unit is used with a Upswung LLC controller.

+ Packed with controller

## Lifting Gate Hinge Site Placement and Layout

### Site Preparations:

The driveway layout below illustrates the general positioning of Lifting Gate Hinge behind the column. The Lifting Gate Hinge is purchased as either a RIGHT HAND or LEFT HAND HINGE, (as viewed from outside the gate). The figure 1 below illustrates a RIGHT HAND hinge installation.

**New Construction:** Drill the piers to allow the placement of Lifting Gate Hinge in close proximity to the finished edge of the gate column if a gate column is used, see figure 2. Drill a pier hole 14" Dia. minimum and 7 feet deep. Remember deeper is better and if the soil is sandy or unstable consult with a soils engineer.

**Existing Column Installation:** Drill the pier to allow the placement of Lifting Gate Hinge in close proximity to the finished edge of the existing gate column, see figure 2. Drill a pier hole 14" Dia. minimum and 7 feet deep. Remember deeper is better and if the soil is sandy or unstable consult with a soils engineer.

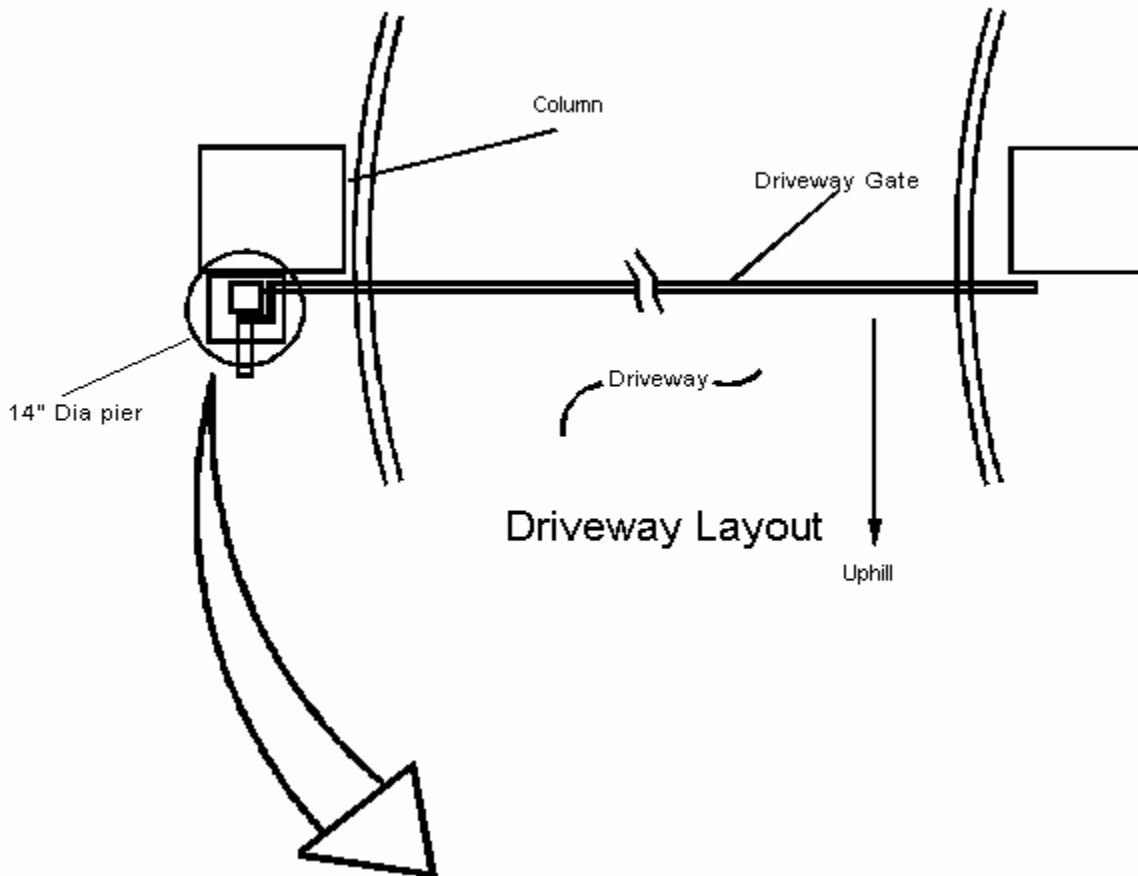

Figure 1

## Pier Construction

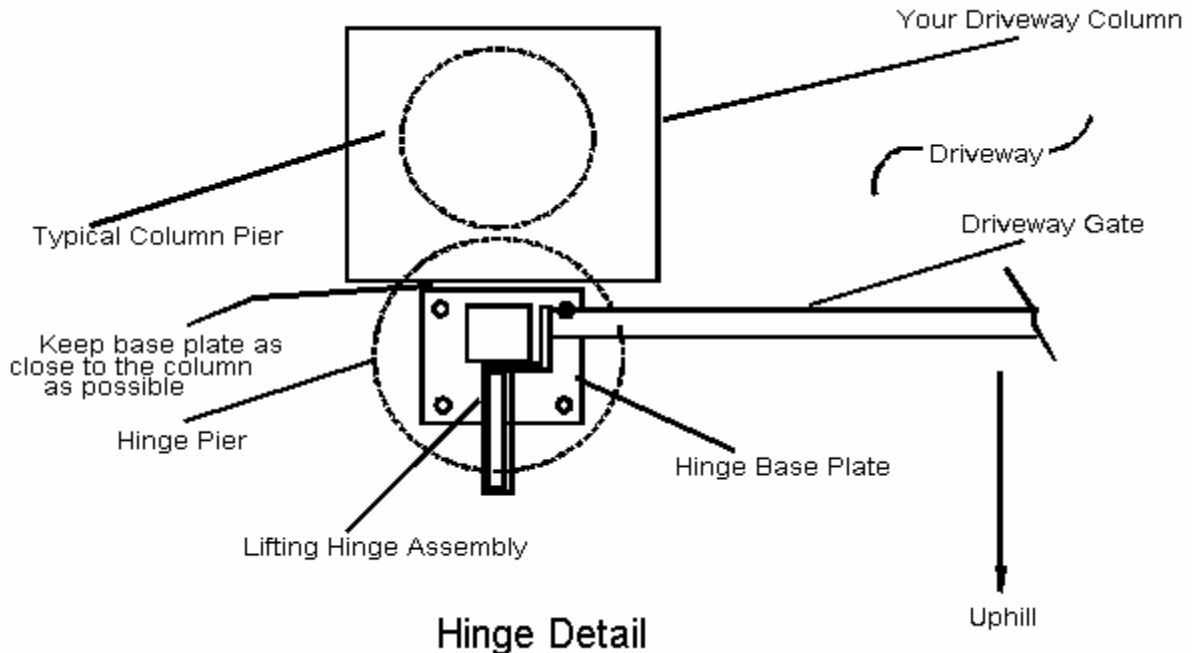

Figure 2



**Concrete work must be performed by an experienced contractor in the trade.  
This work is not intended to be performed by the Homeowner or untrained individuals!**

1. Drill pier hole as close as possible to the existing or proposed column, approximately at a center point behind the column. When determining the best pier placement, set the Lifting Gate Hinge on the ground behind the column to check for clearances and to make sure that the column hides the Lifting Gate Hinge from view at the front of the column.
2. Drill a pier hole 14" Dia. minimum and 7 feet deep. Remember deeper is better and if the soil is sandy or unstable consult with a soils engineer.
3. Use a Sonotube or wood form to bring the concrete pour 3 to 4 inches out of the ground.
4. Use three to four 1/2" rebar measured 2 inches from the bottom of the hole to top of form allowing at least 2" of concrete to surround rebar ends.
5. Prepare a plywood template as dimensioned in figure 3 to precisely hold the anchor bolts in place. Slip the 4- 3/4 " by 24" long anchor bolts through the plywood template and use the nuts to hold anchor bolt threads at least 3 inches out of the concrete for future adjustment.
6. After pouring the pier with 2500 psi concrete, place the prefabricated template with anchor bolts into the concrete insuring that there is good concrete coverage about anchor bolts, and make sure the template orientation (rotation) points the Lifting Gate Hinge in the proper direction as in figure 3.

7. Use quality concrete (2500PSI) or better, don't use post hole concrete ready mix.
8. **Let concrete cure for 3 days or longer in cold weather!!! – do not disturb the anchor bolts.**
9. See figure 4 for the typical layout of a pier.

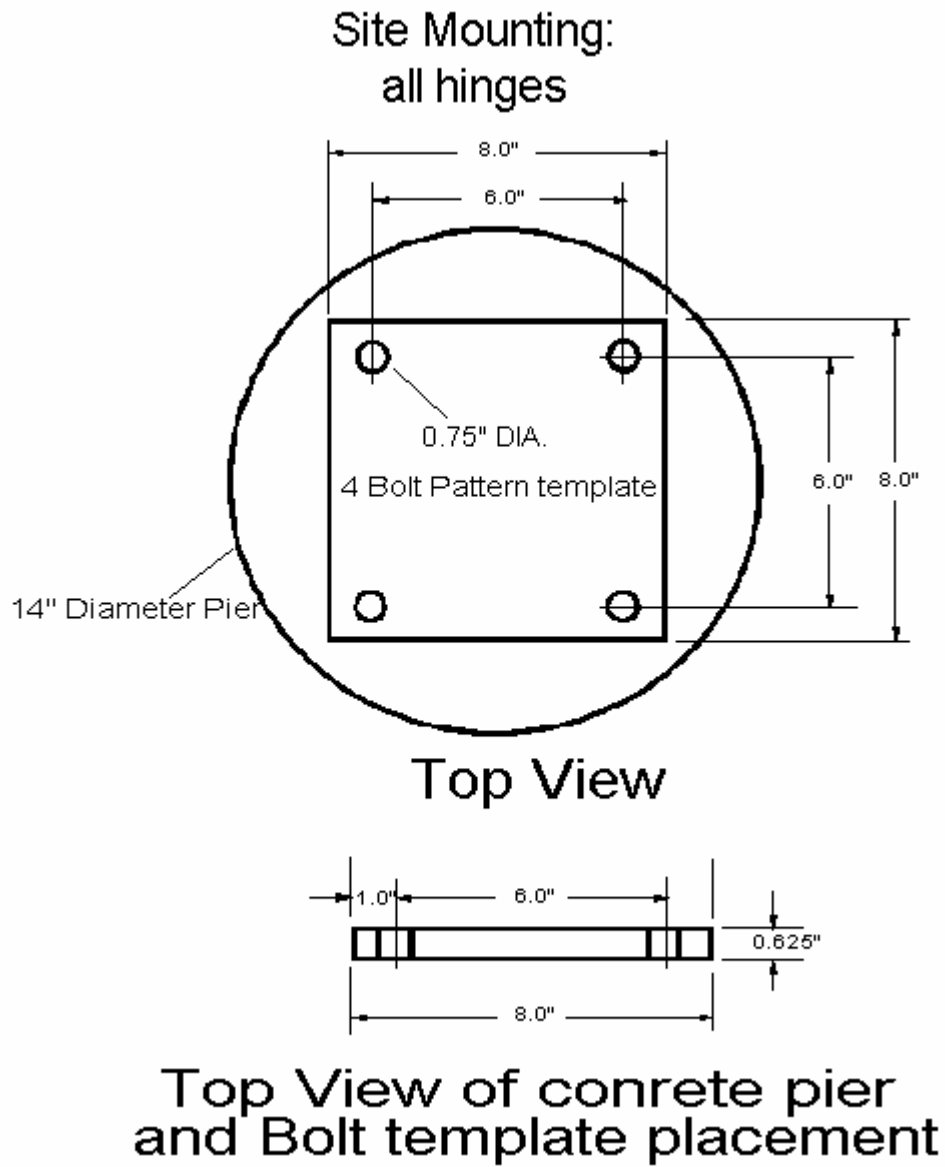
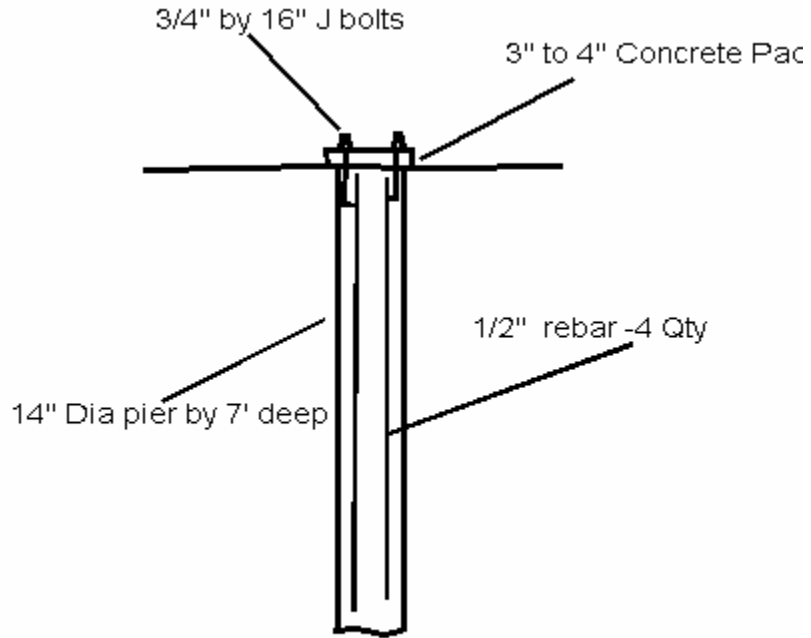

Figure 3



## Side View of concrete pier

**Figure 4**

**Note: The heavier the gate the deeper the pier, if soil is loose or sandy the pier must be deeper. Consult an engineer if soil is not stable. A 7' deep pier is only an average depth for most installations- your conditions may vary.**

**This Space Reserved for notes:**

## Lifting Gate Hinge Mounting



Welding and Mechanical attachments can be dangerous and result in injury or death. These adjustments must be performed by experienced contractors in the trades of Welding and Torsion Spring Doors. This adjustment is not intended to be performed by the Homeowner or untrained individuals!

1. Screw on the base nuts to each of the four threaded studs. The nuts are to be threaded all the way down to the concrete pad. Slip the Lifting Gate Hinge over the four studs until it is firmly seated to the base nuts. Make adjustments to the base nuts to plum the Lifting Gate Hinge.
2. Add to the top nuts and tighten these nuts until the hinge is held firmly (these nuts will be readjusted later). Check again to make sure that the Lifting Gate Hinge is still plum.
3. With Lifting Gate Hinge in the fully closed position, position the gate barrier to the Barrier Weld Flange make the gate barrier is pointed in the direction where the fully closed gate should be pointing<sup>11</sup>.
4. Tack weld the top of the gate barrier to the Barrier Weld Flange, plum the gate barrier and tack weld the bottom.
5. Adjust the gate barrier sag out by adjusting the bottom and top anchor nuts thereby tilting the Lifting Gate Hinge slightly back from the gate barrier direction to lift the sag out while the gate is in the closed gate position. When satisfied the gate barrier sag is out, tighten all nuts to at least 100 ft-lbs (the concrete must be cured at this point!!) and make sure the all the bottom nuts are contacting the Lifting Gate Hinge base plate.
6. When satisfied with the position and the sag of the Gate Barrier then weld both sides of the gate barrier to the Barrier Weld Flange, welding 2 inches and then skipping 2 inches, then welding 2 inches all along the length of the Barrier Weld Flange.
7. Mount the F4 PLUS control box within 3 feet of the Lifting Gate Hinge, making sure that the F4 PLUS control box and the electrical supply do not interfere with the operation of the swing of the gate.

## Counterbalancing the Gate Barrier



The adjustment of torsion springs can be dangerous and result in injury or death. Torsion spring adjustments must be performed by experienced contractors in the trade of torsion spring doors. This adjustment is not intended to be performed by the Homeowner or untrained individuals!



When adjusting Torsion Springs or raising and lowering the Gate Barrier, a safety rope must be used to tie off the Gate Barrier to prevent it from slamming closed on the person(s) working on or around Gate Barrier or Lifting Gate Hinge.

1. With the above steps completed, the Gate Barrier can be balanced. Balancing the Gate Barrier is important to insure long life of the hydraulic operator which doesn't work hard if the Gate Barrier is balanced and if the operator is disengaged the ability to easily push the Gate Barrier out of the way.
2. The balance point is when the Gate Barrier comes to rest in approximately at the 2/3rds of the opening swing to the full open position.
3. Release the Hydraulic Operator by locating the by-pass valve. Using the hex key supplied, dis-engage the by-pass valve by turning it counterclockwise as far as possible to release the Hydraulic Operator (see Hydraulic Adjustments) allowing the gate to move.
4. The Torsion Springs must be tightened to begin balancing the Gate Barrier. Start with either the top or bottom Torsion Spring with cranking bars (hot rolled steel) that can be purchased at your local hardware store. Always tighten the Torsion Spring in the direction of rotation of the opening Gate Barrier.
5. Start by tightening one Torsion Spring to about 50 ft-lbs torque, then tightening the other Torsion Spring to same torque as the first Torsion Spring that was tightened. If the Gate Barrier is not raised to the previously described balance point, add more torque equally to each of the two Torsion Springs in 10 ft-lb steps until balance point is achieved. If the Gate Barrier is raised to beyond the previously described balance point, reduce torque equally to each of the two Torsion Springs in 5 ft-lb steps until balance point is achieved.
6. When tightening the Torsion Spring set bolts make sure the set bolts engage the keyed areas of the Torsion Spring Shaft
7. Completely close the gate, locate the by-pass valve. Using the hex key supplied, re-engage the by-pass valve by turning it clockwise as far as possible.



**NEVER** adjust the open and/or close pressure valves to their maximum setting. Always use the minimum setting required to move the gate. If strong wind loads are a possibility, increase the run time **NOT** the pressure valves.

8. Go to the HYDRAULIC ADJUSTMENTS section to setup the Hydraulic Pressure adjustments.
9. Go to GENERAL WIRING INFORMATION, PRIMARY VOLTAGE WIRING, & CONTROL WIRING SECTIONS to complete wiring connection to Lifting Gate Hinge.

## Other Mounting Information

### Gate Stops

The gate must have a permanent gate stop at the full closed position. It is also highly recommended that there be a gate stop at the determined full open position. These are to prevent the piston from bottoming in the cylinder and prolong the unit's life.

### Rod Cover

A. Install the rod cover over the piston rod, as shown. **IMPORTANT: The cover must be installed to keep the piston rod clean and nick-free.**

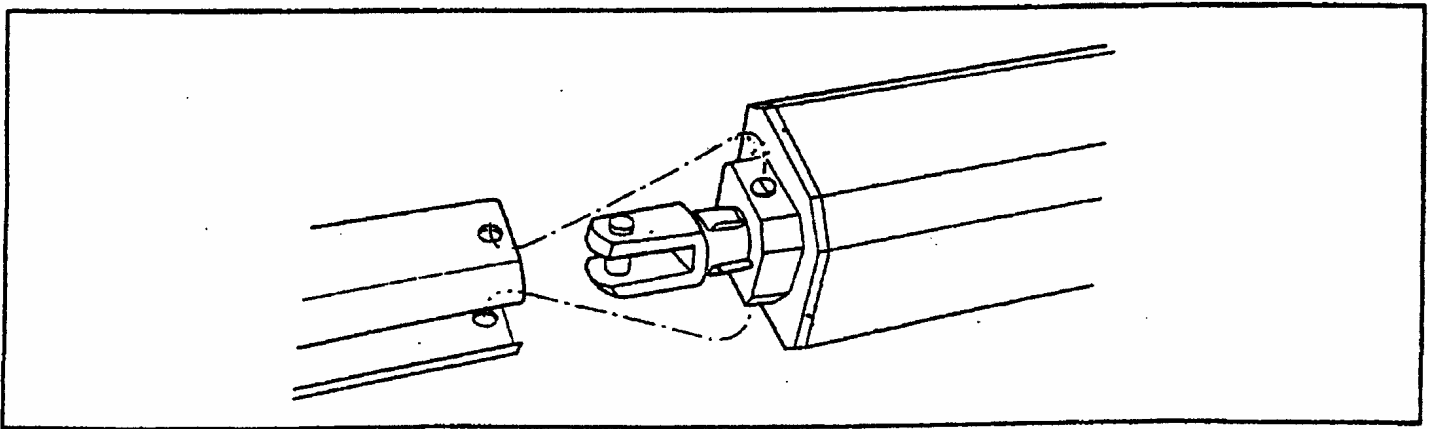

Area Reserved for Notes

## Hydraulic Adjustments

A. Remove the plastic cover from the unit.

B. Locate the by-pass valve. Using the hex key supplied, re-engage the by-pass valve by turning it clockwise as far as possible.

C. Turn power on at main power supply and at power disconnect switch. The controller may have a 7 second delay from power-up until a signal can be received.

D. With gate open, activate the unit to close. Using a flat blade screwdriver, slowly turn the close pressure valve clockwise until the gate begins to move, then adjust it 1/4 to 1/2 turn more. (Unit is shipped with pressure valves set at minimum.)

NOTE: Since the unit's cycle time has yet to be adjusted, it may shut off too soon or may run longer than desired.

NEVER adjust the open and/or close pressure valves to their maximum setting. Always use the minimum setting required to move the gate. If strong wind loads are a possibility, increase the run time NOT the pressure valves.

E. Locate the open pressure valve. Activate the unit to open and adjust it in the same manner as the close direction.

**IMPORTANT:** The open & close pressure valves must be adjusted properly. They should develop enough force to open and close the gate properly. If the gate meets an obstruction there will be a minimum amount of force applied. Check this by holding the gate when it is closing and opening. For manual operation of the gate, use the hex key and turn the by-pass valve counter-clockwise to disconnect the unit. To reconnect the unit, turn the by-pass valve clockwise.

F. When all the valves have been adjusted, replace the plastic cover.

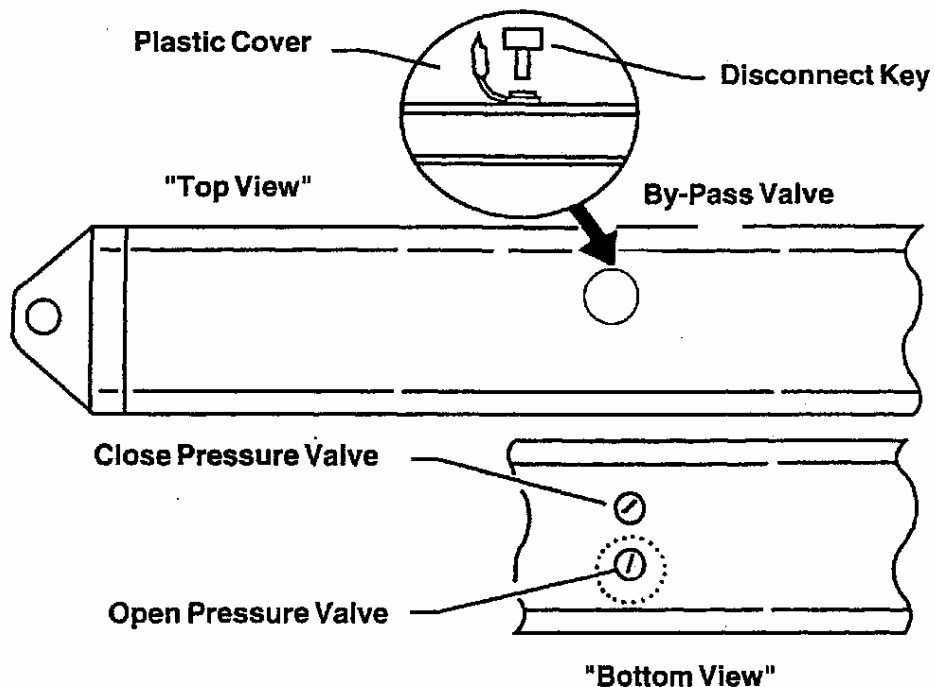

## Specifications & Capacities

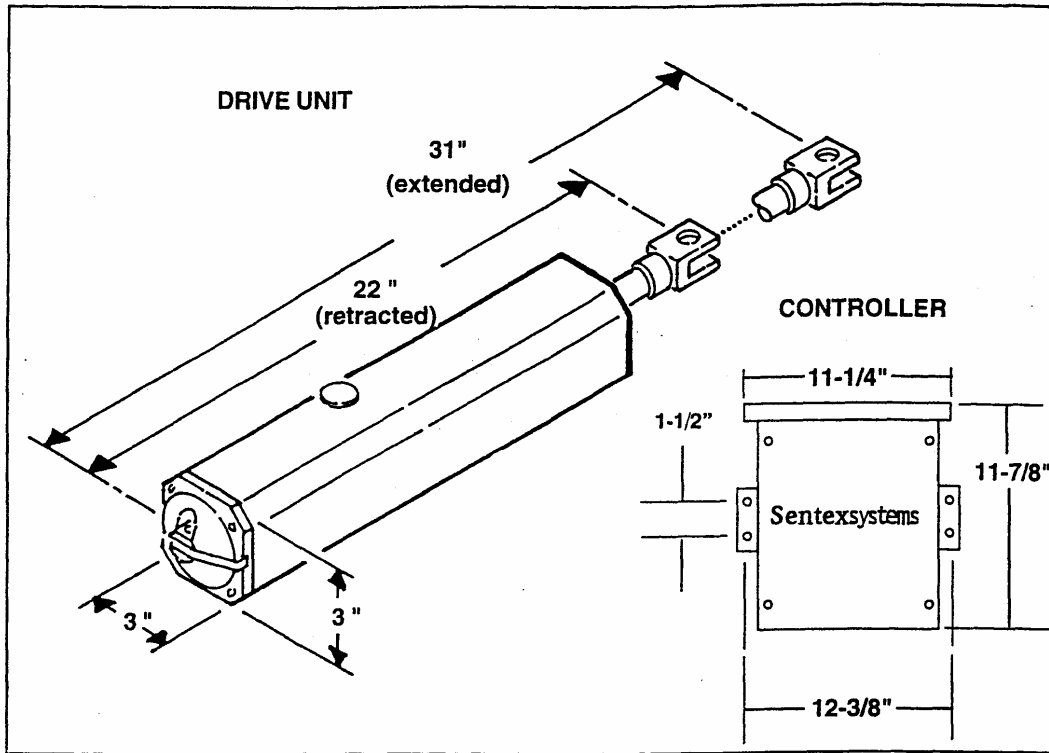

### Maximum Length VS. Maximum Weight

0 to 8 ft	500 lbs
8 to 10ft	300 lbs
10 to 12 ft	250 lbs

The Model HL410-11 is a light duty commercial gate operator designed to operate a typical swing gate. Because operating requirements and gate construction vary by installation, the capacities shown should be used as a guide to determine the expected performance of the unit. Contact an Upswung LLC dealer if your application exceeds any of the recommended limits to determine the proper unit needed.

### Double Check Operator Capacities!

Do not use this operator on "walk or pedestrian" gates. Do Not Misapply Product for other uses. Warranty will be void!

\*Please note that hydraulic locking is not intended to be a replacement for security type locks. External lock systems should be used if:

- a. High security is required for the installation.
- b. The length of the gate exceeds 12 feet.
- c. The gate has a large surface area.
- d. The installation area could have strong or gusty winds.

### Specifications

Cycles per hour (Full open & close) 10 maximum  
 Time to open (Avg.) 20 seconds  
 Close Direction  
 Hydraulic (gate) Locking\*  
 Primary Voltage 120 VAC - 60 HZ  
 Secondary Voltage 24 VAC  
 Power Consumption 335 W (full load)  
 Current 3-1/2 A (full load)  
 Motor R.P.M. 1700  
 Motor Overload 1 350C  
 Fluid Dexron ATF

\*It is highly recommended that you reconsider using this type of gate operator on any solid faced gate, without an external lock system on both the open and closed position. Strong winds will greatly affect the efficiency of this operator on these types of gates.

### Important

The gate must be level and operate smoothly and freely. If it does not, damage to the operator may result and the life expectancy will be greatly reduced.



## Safety Information



Automatic gate operators provide convenience and security to their users. However, because these machines can produce high levels of force, it is important that all installers and users be aware of the potential hazards associated with improperly installed or adjusted units. The information on this page contains various safety precautions and warnings, some highlighted with this symbol. This symbol will identify conditions that can result in serious injury or death. Take time to read and follow these precautions and the other information provided.

**NOTE:** This operator is intended to be apart of a total gate operating system. It is the responsibility of the purchaser and Installer to ensure that the total system is safe for its intended use.

**⚠ PLEASE INSTALL ALL SAFETY DEVICES NECESSARY TO MAKE THIS INSTALLATION AS SAFE AS POSSIBLE.**

<p><b>Before Installation:</b></p> <ol style="list-style-type: none"> <li>1. Check to see that this is the proper operator for this application. (See page 3)</li> <li>2. Ensure that the gate has been properly installed and works freely in both directions. Repair or service any worn or damaged gate hardware.</li> <li>⚠ 3. Install the gate operator on the inside of the property and/or fence line. Do not install an operator on the public side of the gate.</li> <li>4. If the gate is near a residential area, or pedestrian traffic is expected near the gate, additional safety equipment such as electric gate edges or photocell detectors must be installed to prevent entrapment. Severe injury or death can result from entrapment with the gate.</li> <li>⚠ 5. Certain types of gates can create greater hazards to pedestrians. Any gate that has exposed, reachable pinch points or is constructed to allow arms and legs to pass through it is a potential hazard. These hazards should be guarded against.</li> <li>⚠ 6. Review the operation of the unit and become familiar with the manual disconnect system and safety features of the unit.</li> <li>⚠ 7. Outdoor or easily accessed controls should be of the security type to prohibit unauthorized use of the gate.</li> </ol> <p><b>During Installation:</b></p> <ol style="list-style-type: none"> <li>1. Be aware of all moving parts and avoid close proximity to any pinch points.</li> <li>2. Disconnect power at the service panel before making any high voltage power connections.</li> </ol>	<p><b>During Installation:</b></p> <ol style="list-style-type: none"> <li>⚠ 3. Place controls far enough from the gate so that a user can see but cannot touch the gate while operating the controls.</li> <li>4. Place warning signs provided on the gate or in a high visibility area to alert of automatic gate operation.</li> </ol> <p><b>After Installation:</b></p> <ol style="list-style-type: none"> <li>1. Make sure the user understands the basic function Safety features of the systems.</li> <li>2. Leave this manual and the troubleshooting guide with the end user.</li> </ol> <p><b>End User:</b></p> <ol style="list-style-type: none"> <li>⚠ 1. Periodically check all safety systems. If these functions are observed to operate improperly, discontinue use and contact a professional for service immediately.</li> <li>2. Follow recommended maintenance schedule.</li> <li>⚠ 3. Do not allow children to play on or near the gate operating system.</li> <li>⚠ 4. Never operate gate until you have it in full sight.</li> <li>5. See page 12 for pressure valves and manual disconnect information.</li> </ol>
--	---

## General Wiring Information

This a general description of the layout for regular and lifting gates. Your site may require changes to this general layout to be determined by the installer.

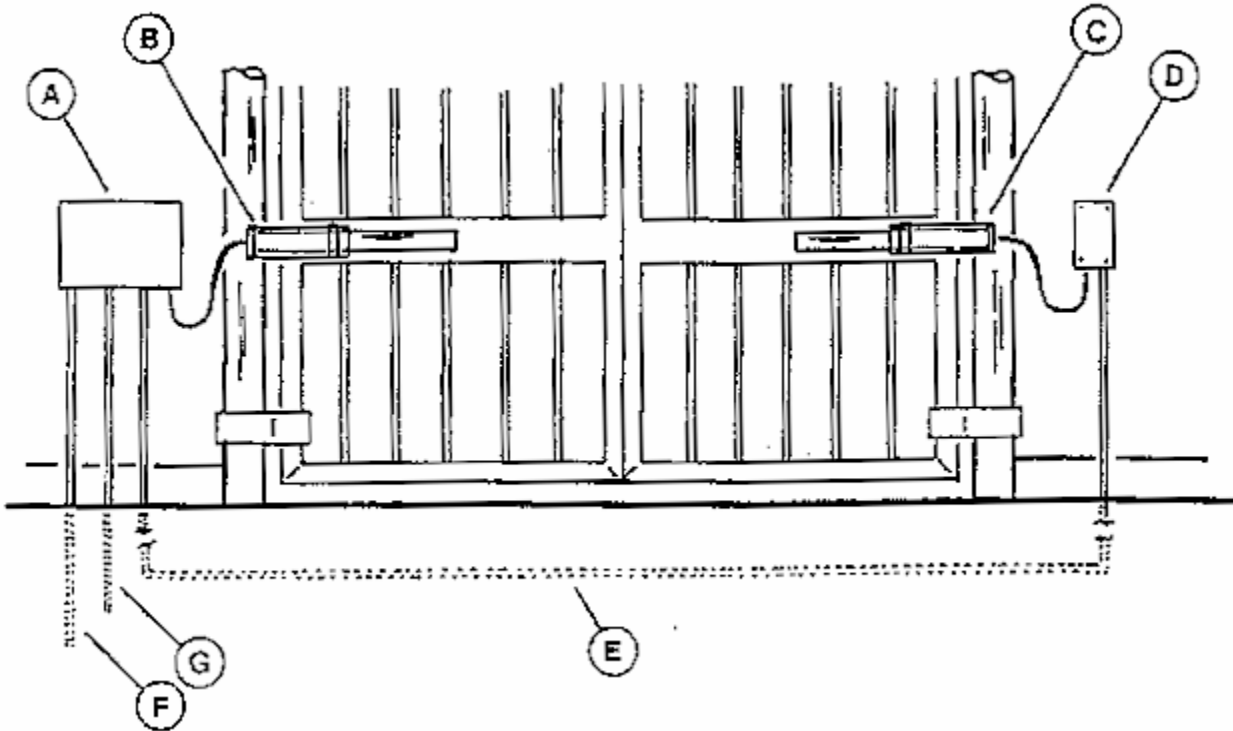

- |  |  |
|--|--|
| <p><b>A - Controller</b><br/> <b>B- Drive Unit</b><br/> <b>C- Drive Unit, Slave Option</b><br/> <b>D- Junction Box, Slave Option</b></p> | <p><b>E- Conduit for Slave (4 wires)</b><br/>         Suggest-10 gauge stranded wire<br/> <b>F- Conduit, Power (3 wires)</b><br/> <b>G- Conduit, Control (as required)</b></p> |
|--|--|

NOTE: Other wire runs may be required, depending on your application.

### Wiring Information

The distance shown on charts is the total length of wire, measured in feet from the control panel to the power source. Do not exceed maximum distance.

1. Supply voltage must be within 10% of the unit's rating under load conditions. (Measure voltage at the unit.)
2. Connect power in accordance with local codes.
3. Wire tables are based on stranded copper wire. Wire insulation must be suitable to application.
4. All units', single and master/slave, must be properly grounded with a supply grounding conductor.
5. Do not run control wires in the same conduit with power wires.
6. Do not use solid copper wires for controls.

<b>Power Wiring</b>		
<u>Maximum Distance</u>		<u>Wire Gauge</u>
Single unit	Dual unit	
200ft	100ft	10
310 ft	155ft	8
500ft	250 ft	6
<b>Control Wiring</b>		
200ft		18
400ft		16

Do not use parallel conductor cable.

If PVC type conduit is used in a single trench, allow a minimum of six (6) inches between lines.

## Primary Voltage Wiring

**⚠ CAUTION:** Make sure power is disconnected at main power supply and at power disconnect switch on operator before continuing.

**Note:** Terminal strips unplug for easy wire connection, make sure you plug them correctly and don't offset the terminal strip in the terminal strip socket.

<p>A. Connect 120 VAC, single phase power, black wire to terminal 10, white wire (neutral) to terminal 9 and ground wire to terminal 11.</p>	<p><b>For Optional Master/ Slave</b> Connect the control cord from the slave unit to the junction box then connect from the junction box to the Power wiring terminal strip, as shown.</p>
<p>B. Connect the control cord from the opener unit to the power terminal strip as shown in the <b>TERMINAL CONNECTIONS TABLE</b> and <b>CONTROL PANEL LAYOUT</b> schematic.</p>	<p><b>⚠</b> All Outdoor 120 VAC connections must be in water-tight conduit as per local building codes. Consult your local building department for your local building code requirements.</p>

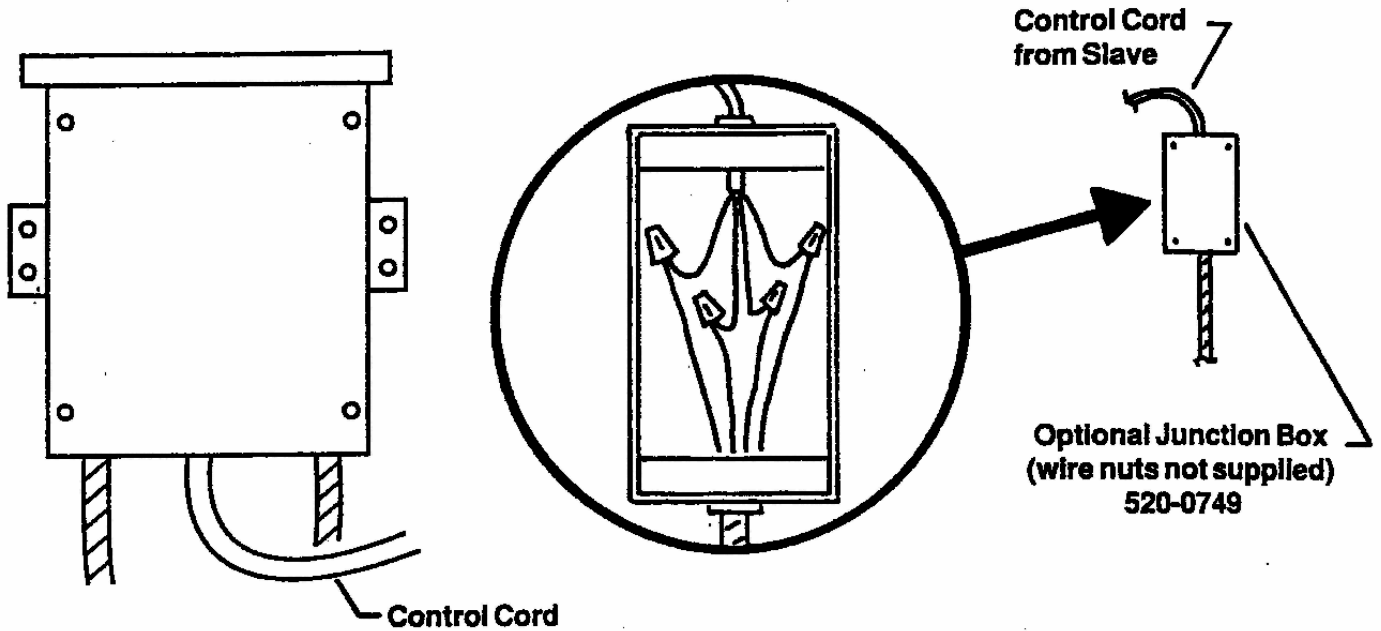

**Conduit Locations May Vary**

## Control Wiring

All controls that are to be added must be connected to the control wiring terminal strip as shown CONTROL PANEL LAYOUT AND TERMINAL CONNECTIONS BELOW.

 PLEASE INSTALL ALL SAFETY DEVICES NECESSARY TO MAKE THIS INSTALLATION AS SAFE AS POSSIBLE.

### Terminal Strip Connections

Note: Terminal strips unplug for easy wire connection, make sure you plug them correctly and don't offset the terminal strip in the terminal strip socket.

1-	MOT 1A Brown wire from Opener	16-	LIMIT SWITCH input- closes opener-motor 1 (NC)
2-	COM1 Blue wire from Opener	17-	LIMIT SWITCH input- opens opener-motor 1 (NC)
3-	MOT 1C Black wire from Opener	18-	PHOTOCELL input (NC)
4-	MOT 2A Brown wire from 2 <sup>nd</sup> Opener	19-	START input (NO) momentary contact
5-	COM2 Blue wire from 2 <sup>nd</sup> Opener	20-	24VAC output for accessories, (2- photocells & 1 Radio receiver) -8W max.
6-	MOT 2C Brown wire from 2 <sup>nd</sup> Opener	21-	24VAC common 0V for power supply of PHOTOCELLS, ACCESSORIES, & ELECTRIC LOCK
7-	LAMP output	22-	12VAC output for electric lock 15w max
8-	LAMP output	23-	STOP Input (NC)
9-	115V 60H Line Input Neutral ( WHITE WIRE)	24-	PEDESTRIAN GATE START input- motor1 (NO)
10-	115V60H Line input Phase (BLACK WIRE)	25-	COMMON Input for: STOP-START-START PEDESTRIAN GATE
11-	GROUND – Green wire from openers	26-	ANTENNA BRAID GROUND
12-	GROUND – ground wire from line input	27-	ANTENNA CORE WIRE
13-	COMMON for: FA1, FC1, FC2, FA2 & Photocell inputs	28/ 29	RELAY CLEAN CONTACT to: Connect a flashing light with fixed light drawing power from the terminals 7 & 8 (the relay flashes fast during opening and closing) control a warning light to signal gate movement. Connect a 24VAC lamp powered by terminals 20-21 (1 watt max.)
14-	LIMIT SWITCH input- closes opener motor 2 (NC)		
15-	LIMIT SWITCH input- opens opener motor 2 (NC)		

### Installation Notes:

A) This installation is to be supplied by a GFI circuit breaker of 10A ( check with your local building dept. for the proper wiring procedures). The switch must guarantee omni polar separation of the contacts with an opening distance of at least 3 mm.

B) Differentiate and keep the power cables (minimum cross-section 1.5mm<sup>2</sup> ) separate from the signal cables which may be 0.5mm<sup>2</sup>.

C) Make the connections referring to the TERMINAL TABLE above and the following CONTROL PANEL LAYOUT.

D) Be very careful to connect in series all the devices that are connected to the same NC (normally closed) input and in parallel all the devices that share the same NA (normally open) input.

### Connections Terminal Board:

- A. STOP Input terminal 23 can be jumped to terminal 25 COMMON to bypass the safety stop switch for testing, but a safety stop switch is required for the safe operation of this gate!
- B. The large motor capacitor is connected between terminals 1-3 (Motor Opener 1) and 4-6 (Motor Opener 2).

## Trimmer Adjustment:

1. If the system controls a double-gate system with phase shift (V3 turned clockwise), motor opener 1 starts opening two seconds before motor opener, during closing movement delay is set by adjusting trimmer V3.

There are 4 trimmers (V1-V2-V3-V4) on the F4PLUS control unit to adjust the following:

V1	FORCE	Turned clockwise it adjusts the motor torque from 40% to 98% for the first 3 seconds of opener startup.
V2	RUN TIME	Turned clockwise, it adjusts the RUN TIME from 2 to 100 seconds.
V3	PHASE SHIFT TIME	Turned clockwise, it adjusts the delay between the start of the closing movement of motor opener 2 and motor opener 1 (from 0 to 20 seconds). The phase shift during opening is fixed at 2 seconds. With V3 set to minimum the delays are cancelled both during opening and closing (double sliding gate version) and water power boost function is disabled.
V4	PAUSE TIME	Turned clockwise it adjusts the PAUSE TIME from 2 to 100 seconds. Adjusted to minimum, it disables the pause time= STEP-BY-STEP function

## Programming Functions:

Default settings: DIP SWITCHES 1, 2, 3, 9, 10 OFF; DIP SWITCHES 4, 5, 6, 7, 8 ON Trimmer V1 adjusted to maximum, Trimmers V2, V3 and V4 adjusted to half their travel.

DIP 1	ON	When the photocell is intercepted, both during opening and closing, the gate motion is locked until the photocell is freed. Subsequently, there is an opening phase.
DIP 1	OFF	The photocell stops and immediately reverses the motion of the gate during the closing phase, while in the opening phase it has no effect.
DIP 2	ON	Enables multi-user function, i.e. one START command opens the gate, and no other START command are accepted during the opening. During PAUSE, one START command reloads the pause time. During closing, one START command reopens the gate. Re-closing occurs only in automatic mode after the pause time, also when V4 is on minimum.
DIP 2	OFF	Enables the STEP-BY-STEP function (one START command OPENS, a second command STOPS, a third command CLOSES the gate) or STEP-BY-STEP with AUTOMATIC RE-CLOSING depending on how trimmer V4 is positioned: <ul style="list-style-type: none"> <li>• If turned completely counterclockwise= STEP-BY-STEP</li> <li>• If turned clockwise= STEP-BY-STEP with RE-CLOSING i.e. after the pause time it re-closes automatically. To close with the remote control during the pause, two start commands must be given ( the first command sets the gate to stop).</li> </ul>
DIP 3	ON	Enables a POWER BOOSTER function- exercises a brief thrust closing and before opening, facilitating release of the electric lock ( if the limit switches are used, this function is disabled).
DIP 9	ON	The outputs 7-8 of the terminal board are used to control FLASHING LIGHT equipped with its own flashing circuit.
DIP 9	OFF	The outputs of 7-8 of the terminal board become outputs for the COURTESY LIGHT and remain active for 3 minutes after the run time (max. 100 w). In this mode the terminals 28-29 can be used to connect a FLASHING LIGHT without flashing circuit.
DIP 10	ON	Enables PEDESTRIAN GATE OPENING with 2 <sup>nd</sup> key of the remote control. (F4 plus/RR only).

## LIMIT SWITCH CUTOUPS- limit switches not used.

DIP 4	ON	Cuts out limit switch input- opens motor opener 1
DIP 5	ON	Cuts out limit switch input- closes motor opener1
DIP 6	ON	Cuts out limit switch input- opens motor opener 2
DIP 7	ON	Cuts out limit switch input- closes motor opener 2
DIP 8	ON	Cuts out photocell input

**WARNING!! IN THE EVENT OF A SYSTEM WITH ONLY ONE MOTOR OPENER AND USING THE LIMIT SWITCHES, THE DIP SWITCHES 4,5,6, AND 7 MUST ALL BE SET TO OFF, WHILE IF USING ONLY ONE TYPE OF LIMIT SWITCH, E.G. Fa1 and/or Fa2, ENABLE (OFF position ) FOR THE CORRESPONDING DIP SWITCH.**

## Final checks and testing

Before powering the control unit, check the following:

- 1) Check that the dip switches and trimmers have been set properly according to requirements.
- 2) Check the electrical connections; Improper connection may cause damage to the control unit and the operator.

### Power the devices

- 3) Check that the 5 red LEDs of the safety devices are on and the yellow LEDs off
- 4) Check that when engaging any limit switches used the corresponding LEDs come on.
- 5) Check that when passing through the beam of the photocells the corresponding LED goes off.
- 6) Check that the motors are locked and ready for operation. Remove any obstacles from the operating range of the gate, then give the START command. Upon the first command, the control unit starts an opening phase; check that the motor rotation direction is correct if not, invert the wires of terminals 1-3 and/or 4-6.
- 7) Fine adjust the trimmers.

### Radio Module

#### Code learning:

When powering the control unit for the first time, check that the red code learning LED is on, indicating that the receiver is ready to learn a remote control (whether DIP SWITCH or Rolling-Code with automatic recognition of the type).

One of the keys of a transmitter can now be pressed (1-2-3 or 4).

When the code has been learned, a command is given to the control unit.

Without pressing the CH1 key again, further remote controls of the same family can be learned, one after the other.

After learning the last remote control, wait for the LED to go off (about 6 seconds) indicating that the system has exited TX learning and is ready to operate normally.

**WARNING:** After learning the first code, the system will accept only that family of codes (if the first is Rolling all the others must be Rolling). If learning is for DIP SWITCH transmitters, only one remote control needs to be learned.

**MEMORY RESET:** If a mistake is made or all the codes need to be deleted, press the CH1 key (the red LED comes on) and hold it pressed down until the LED goes off again. When the key is released, the LED flashes (indicating that the memory is empty) and then comes back on, indicating that the system is ready to learn a new remote control (whether DIP SWITCH or Rolling-Code).

When learning a remote control key, which is positioned on channel 1 (the one which controls full opening of the gate), the system automatically learns the 2nd key of the remote control which, if enabled with DIP10 (ON), controls the PEDESTRIAN GATE START.

#### Remote control learning without accessing the control unit:

After letting the system learn a remote control in manual mode (by pressing the key S1), self-learning of other remote controls of the same family can be enabled by simultaneously pressing (for 2 seconds) the keys 1 and 2 of the transmitter already learned. Subsequently, when pressing the key of a new remote control it is self learned. Learning has been successful when it moves the gate.

# CONTROL PANEL LAYOUT

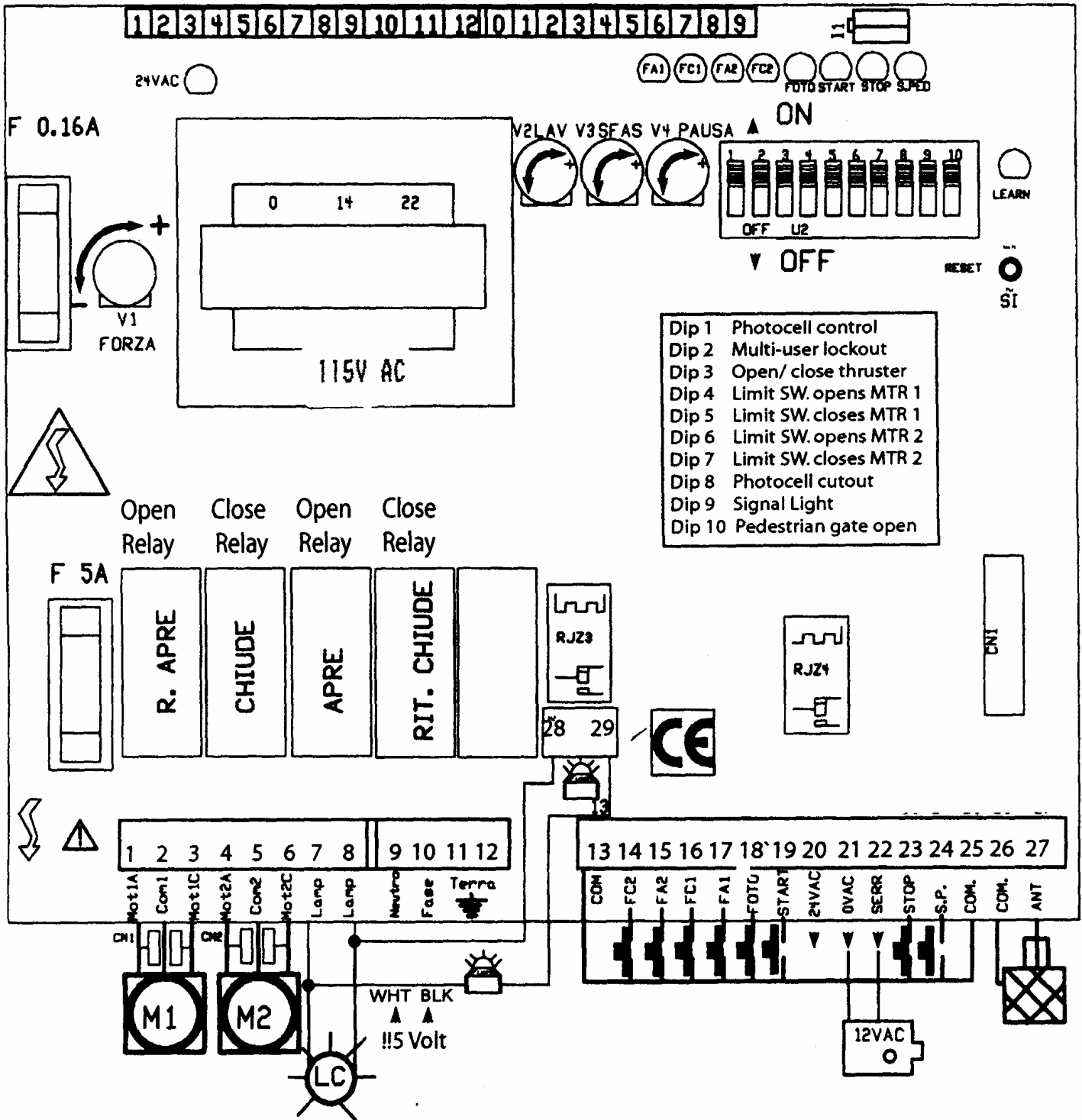

Note: All 5 red LEDs must be on before the operator will run.

## Troubleshooting

Before any installation or maintenance operation, ensure that the power supply has been disconnected.!!

FAULT	POSSIBLE CAUSES and SOLUTIONS
Red 24 Vac LED off	Check that 115Volt power supply and the relevant fuse F1(5A)
The operator does not open or reclose	Check that the red LEDs are on (except the LED of the limit switch active at that moment) and the yellow ones off,
The Flashing Light is on but the gate does not move.	Start has been pressed with the photocells engaged. Check that the photocells are not engaged; once released the gate will start moving.
Red LEDs – FA1-FC1-FA2-FC2-PHOTOCELL off	Check that the relevant inputs and safety switches are connected(FA1-FC1-FA2-FC2-PHOTOCELL or the relevant DIP SWITCH set to ON. Check the fuse F2 (0.16A).
Red STOP LED off	Check that the STOP input is connected to an NC button or that a jumper has been connected between the terminals 23 and 25 (WARNING: the STOP intervention causes a functional stop and NOT a safety stop).
Yellow LEDs always on	Check that the START and PEDESTRIAN GATE inputs have been connected to (NO) buttons.
After the run time the gate does not reclose	Check that the trimmer V4 (Pause) is not turned completely anticlockwise.
After the motors have stopped, the FLASHING LIGHT connected to terminals 7-8 does not go off.	Check that DIP9 is set to ON If only 2 limit switches are used, the relevant DIP SWITCHES must set to OFF, the other 2 to ON.
When the 2nd key of the remote control is pressed, the pedestrian gate is not activated	Check that DIP10 is set to ON
The gate does not perform a phase shift when it starts	Check that the trimmer V3 (closing delay) is not turned completely counterclockwise.
The transmitter has a small range	Check that the antenna has been positioned properly (braid terminal 26, core terminal 27.if a built-in radio or AU01630N receiver is used) (if an AU01710 plug-in receiver is used, the antenna must be connected to the terminals on the receiver). Check that there are no sources of disturbances in the vicinity which limit the range.
The card does not learn the TX code	Check the maximum number of codes that can be stored (200). Check if remote controls of the same family as the first are being learned: DIP SWITCH or ROLLING. Check that the frequency of the radio control is the same as the receiver.
When key 2 of the TX is pressed, both yellow LEDs come on (START and PEDESTRIAN GATE)	The remote control has been learned by pressing the 2nd key and hence both the 1st channel and the 2nd channel are controlled by key 2. Reset the memory and relearn the transmitters.

### Warnings:

While wiring or inserting the RADIO MODULE, the control unit must not be powered. Use of this control unit must rigorously conform to the reference technical regulations. Installation and/or maintenance must be carried out only by qualified personnel in observance of the FCC regulations. The manufacturer cannot be held responsible for any damage caused by improper and/or irrational use .

Upswung LLC declines all responsibility for any inaccuracies contained in this manual and reserves the right to make modifications – without prior notice.

## Rod Cover

A. Install the rod cover over the piston rod, as shown. **IMPORTANT: The cover must be installed to keep the piston rod clean and nick-free.**

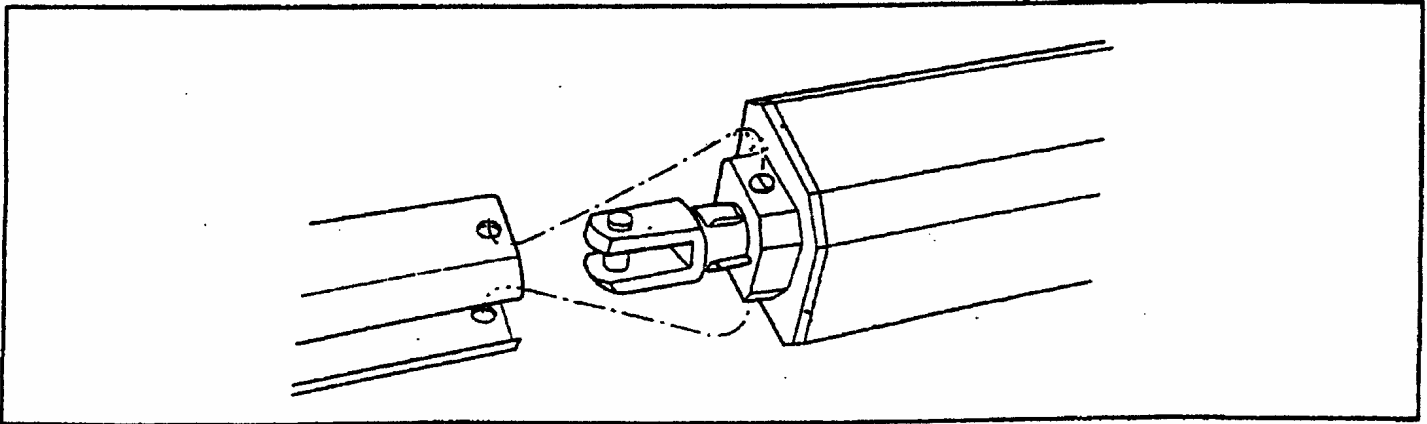

## System Check-Out

### System Check-Out

Upswung LLC strongly recommends that at this time you check out the entire system.

1. Make sure the unit fully opens and closes the gate properly.
2. Check all controls that activate the gate to ensure they are working properly.
3. It is extremely important that all safety devices be checked and double checked.
4. Double check the manual operation features and pressure valves of the system. NOTE: If a problem should arise, see Model HL410 Troubleshooting Guide.

And Finally.....

- Install the gate caution signs on both the inside and outside of the gate where they can be easily seen.
- Make sure the unit and controller are free of grease or dirt. Clean, if necessary.
- Clean up the area around the gate.
- Look around for any tools or equipment that may be left.
- Please leave this manual and the troubleshooting guide with the customer.

Let the customer know you've finished installing the unit and review all pertinent information, including safety features and maintenance, with them.

### LIMITED ONE-YEAR WARRANTY

Upswung LLC gate operators are warranted against deficiencies in material and workmanship for a period of one (1) year from date of purchase, providing recommended installation and maintenance procedures are followed. This warranty is in lieu of all other warranties expressed or implied (some states do not allow limitations on how long an implied warranty lasts, so this limitation may not apply to you) and shall be considered void if damage was due to improper installation or use, connection to improper power source, or if damage was caused by fire, flood or lightning. The manufacturer will not be responsible for any labor charges incurred in the removal or replacement of deficient parts.

In case of failure due to deficiencies in material or workmanship during the warranty period, the complete gate operator will be repaired or replaced at the manufacturer's option. New or factory rebuilt replacements will be used. Replacement parts are warranted for the remaining portion of the original warrant period. Upswung LLC will pay freight on our return of repaired or replaced items in warranty. For information on how to obtain replacement parts or a replacement operator under terms of this warranty contact Upswung LLC, PO Box 2713, Stateline, NV. 89449

This warranty gives you specific rights, and you may also have other rights which vary from state to state.

## Model HL410-11 Parts List

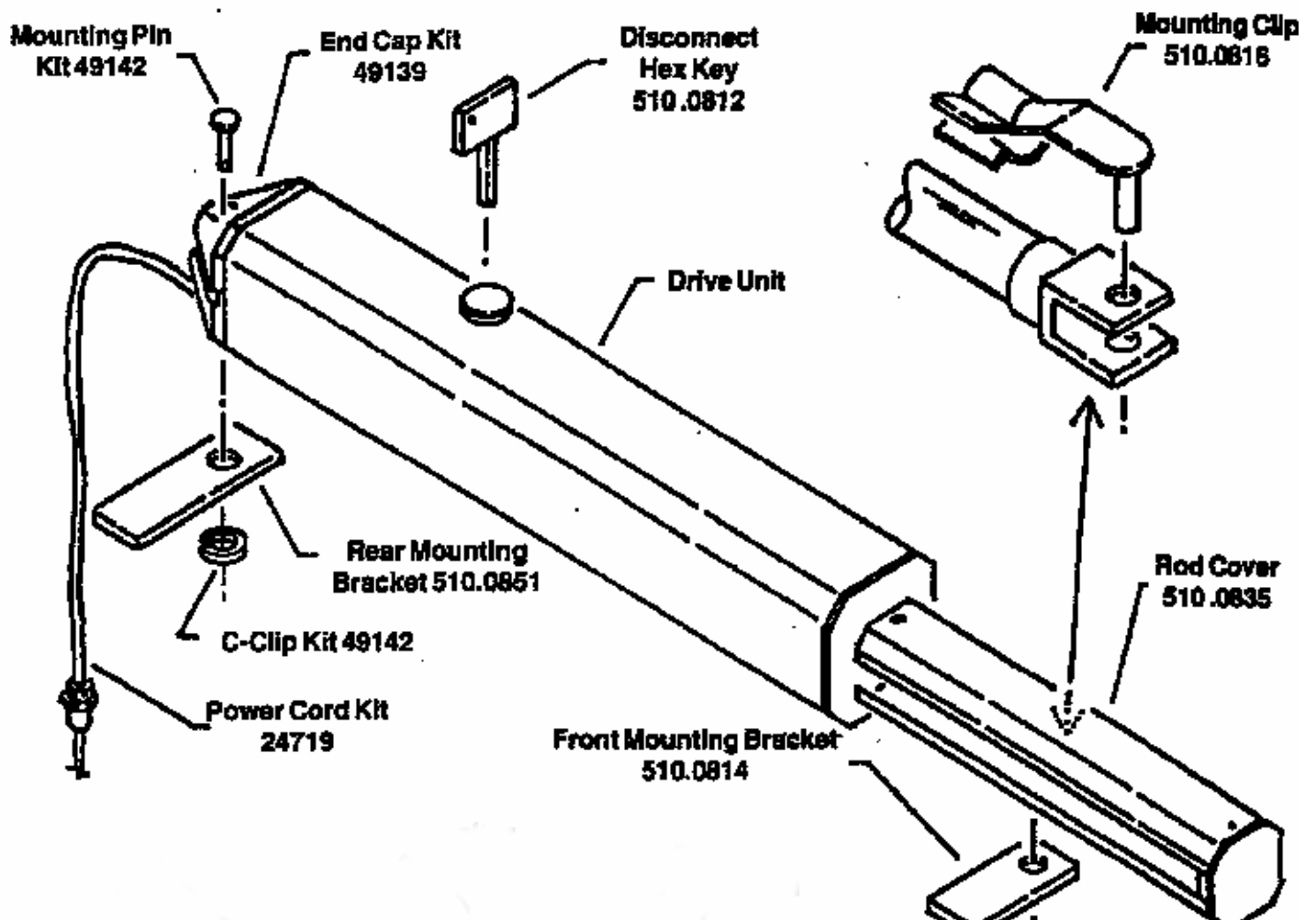

## Required Maintenance Services

	Maintenance Service Required Every-	1-month	6-months	12-months
Gate	Inspect for wear and/or damage	0		C O M P L E T E  C H E C K
Manual Operation	Check & adjust if required		0	
Close Pressure	Check & adjust if required	0		
Open Pressure	Check & adjust if required	0		
Fluid Level	Contact factory		0	
Accessories	Inspect & test		0	
 Safety Devices	Inspect & test	0		

- Inspection and service should be performed anytime a malfunction is observed or suspected.
- High cycle usage will require more frequent service checks.



• ALWAYS DISCONNECT POWER WHEN SERVICING!!

- Use only EXXON Superflo or Dexron ATF (Automatic Transmission Fluid).

Your Professional Upswung dealer is: